

AP Calculus Summer Review Packet

Oxbow High School

2010

Name _____

The problems in this packet are designed to help you review topics that are important to your success in calculus. All work must be shown for each problem. The problems should be done correctly, not just tried. You are expected to get each problem correct. Use your notes from previous math courses to help you. The internet has many good sources for information on these topics.

Do not use your calculator to solve these problems. AP Calculus tests your knowledge of mathematics without using a calculator as well as with a calculator. After you have answered each question (especially the graphs) without using your calculator, you may use your calculator to check your work. If you use your calculator as a crutch, instead of a tool, and just copy from the screen, you will lose this valuable diagnostic help. Please study the correct graphs so that you will be able to work with them without needing your calculator.

You will be tested on the review material contained in this packet during the first week of school. Please spend an appropriate amount of time working on the problems before school begins so that you can be successful on the first test!

Additional copies of this review packet can be printed from the Course website at:

<http://danlemay.net/apcalc/>

email: dlemay@oxbowhs.org

Bring this completed packet with you on the first day of Calculus class!

Get ready for Calculus, an exciting adventure in learning mathematics!

BTW: You do need a Graphing Calculator for this course. A TI-83Plus or a TI-84Plus are the best choices.

Section 1: Simplify Show the work that leads to your answer

1. $\frac{3x^2+10x+8}{6x^2+17x+10}$

2. $\frac{x^3-8}{x-2}$

3. $\frac{5-x}{x^2-25}$

4. $\frac{2x^2-5x-12}{x^2-16}$

Section 2. Simplify each expression

5. $\frac{1}{x+h} - \frac{1}{x}$

6. $\frac{\frac{2}{x^2}}{\frac{10}{x^5}}$

7. $\frac{\frac{1}{3+x} - \frac{1}{3}}{x}$

8. $\frac{2x}{x^2-6x+9} - \frac{1}{x+1} - \frac{8}{x^2-2x-3}$

Section 3: Complete the following trig identities

9. $\sin^2 x + \cos^2 x =$ _____

10. $1 + \tan^2 x =$ _____

11. $\cot^2 x + 1 =$ _____

12. $\sin 2x =$ _____

13. $\cos(2x) =$ _____ or _____ or _____

Section 4. Solve for z

14. $4x + 10yz = 0$

15. $y^2 + 3yz - 8z - 4x = 0$

Section 5. If $f(x) = \{(3,5), (2,4), (1,7)\}$
 $g(x) = \sqrt{x-3}$
 $h(x) = \{(3,2), (4,3), (1,6)\}$
 $k(x) = x^2 + 5$ determine each of the following

16. $(f + h)(1) =$

17. $(k - g)(5) =$

18. $(f \circ h)(3) =$

19. $g(k(3)) =$

20. $f^{-1}(x) =$

21. $k^{-1}(x) =$

22. $\frac{1}{f(x)}$

23. $k(x) \cdot g(x)$

Miscellaneous: Follow the directions for each problem:

24. Expand $(x + y)^3$

25. Simplify $x^{\frac{3}{2}}(x + x^{\frac{5}{2}} - x^2)$

26. Evaluate $f(x+h)$ if $f(x) = x^2 - 2x$

Section VI Simplify

27. $\frac{\sqrt{x}}{x}$

28. $e^{\ln 3}$

29. $e^{1 + \ln x}$

30. $\ln 1$

31. $\ln e^7$

32. $\log_3\left(\frac{1}{3}\right)$

33. $\log_{-2} 8$

34. $\ln \frac{1}{e}$

35. $e^{3 \ln x}$

36. $\frac{4xy^{-2}}{12x^{-\frac{1}{3}}y^{-5}}$

37. $27^{\frac{2}{3}}$

38. $(5a^{\frac{2}{3}})^{\frac{3}{2}}$

39. $(4a^{\frac{5}{3}})^{\frac{3}{2}}$

Section VII Using the point-slope form $y - y_1 = m(x - x_1)$, write an equation for each line.

40. with slope of -2, containing the point (3, 4)

41. containing the points (1, -3) and (-5, 2)

42. with slope 0, containing the point (4, 2)

43. perpendicular to the line in problem #1, containing the point (3, 4)

Section VIII Without a calculator (as for the entire packet), determine the value of each expression.

44. $\sin 0$

45. $\sin \frac{\pi}{2}$

46. $\sin \frac{3\pi}{4}$

47. $\cos \pi$

48. $\cos \frac{7\pi}{6}$

49. $\cos \frac{\pi}{3}$

50. $\tan \frac{7\pi}{4}$

51. $\tan \frac{\pi}{6}$

52. $\tan \frac{2\pi}{3}$

53. $\cos(\sin^{-1} \frac{1}{2})$

54. $\sin^{-1}(\sin \frac{7\pi}{6})$

55. $\sin(\arctan \frac{-3}{4})$

Section IX: For each function, determine the domain and range.

56. $f(x) = \sqrt{x-4}$

57. $g(x) = \sqrt{x^2-4}$

Domain _____

Domain _____

Range _____

Range _____

58. $f(x) = \sqrt{4-x^2}$

Domain _____

Range _____

59. $f(x) = \sqrt{x^2+44}$

Domain _____

Range _____

Section X: Determine the coordinates of all points of intersection of:

60. $y = x^2 + 3x - 4$ and $y = 5x + 11$

61. $y = \cos x$ and $y = \sin x$ in the first quadrant

Section XI: Solve all equations below for x , where x is a real number.

62. $x^2 + 3x - 4 = 14$

63. $\frac{x^4 - 1}{x^3} = 0$

64. $(x-5)^2 - 9 = 0$

65. $2x^2 + 5x = 8$

66. $x^2 - 2x - 15 < 0$

67. $\frac{x-3}{x-1} \leq \frac{4}{x+8}$

68. $12x^2 = 3x$

69. $\sin 2x = \cos x$ hint: refer to section 3 #12

70. $|x-3| < 7$

71. $(x+1)^2(x-2) + (x+1)(x-2)^2 = 0$

72. $27^{2x} = 9^{x-3}$

73. $\log x + \log(x+3) = 1$

Section XII: Sketch each equation (Using max/mins/zeros). Give its domain and range. Scale all graphs using one line equals one unit unless a scale is provided.

74. $y = \sqrt{x}$

75. $y = \sqrt[3]{x}$

Domain _____

Domain _____

Range _____

Range _____

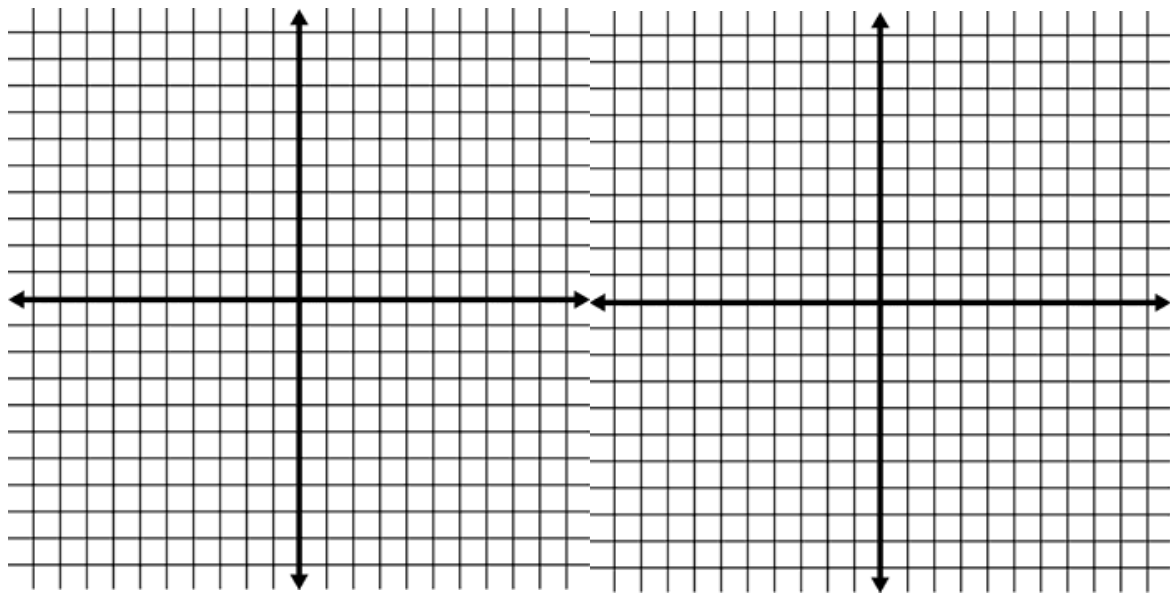

76. $y = |x+3| - 2$

Domain _____

Range _____

77. $y = e^x$

Domain _____

Range _____

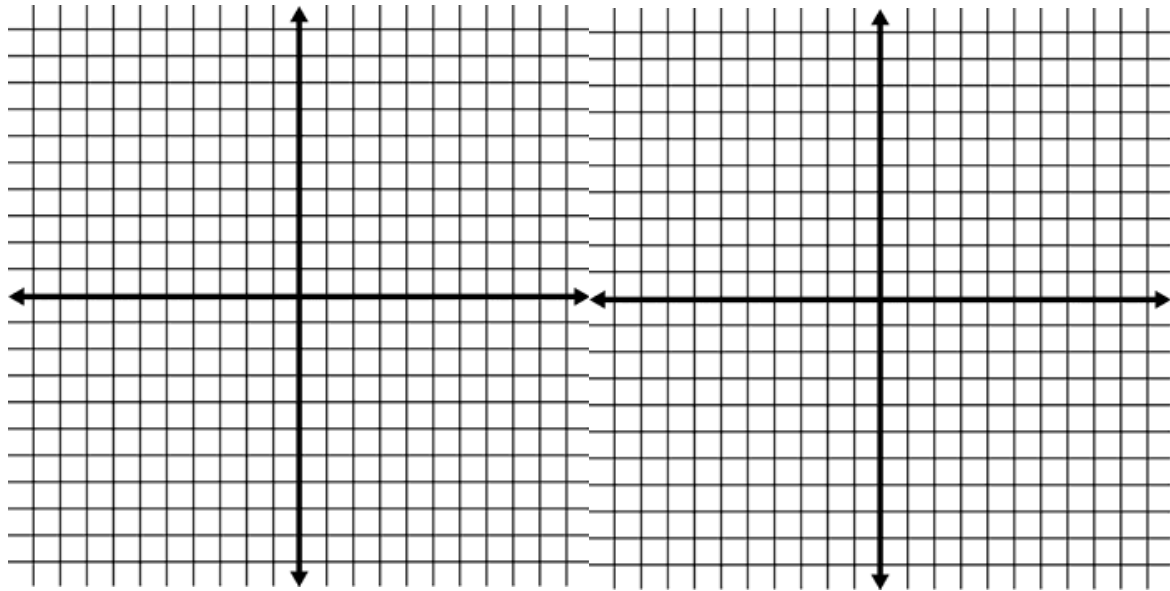

78. $y = \frac{1}{x}$

Domain _____

Range _____



79. $y = \begin{cases} x^2; & x < 0 \\ x+2; & 0 \leq x \leq 3 \\ 4; & x > 3 \end{cases}$

Domain _____

Range _____

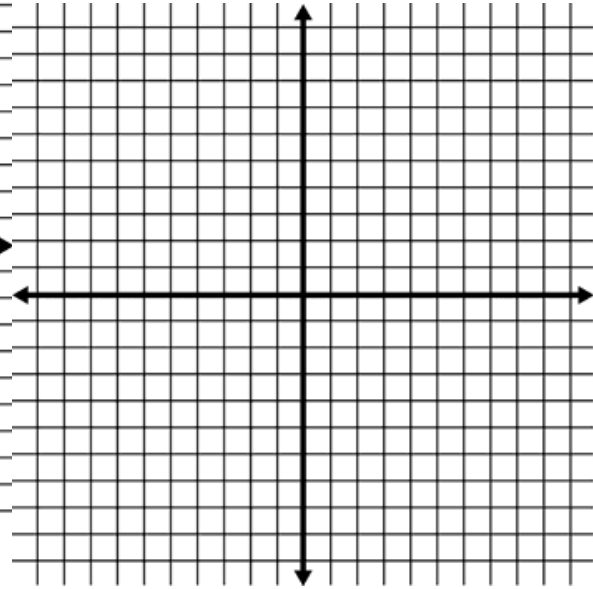

80. $y = \sin x$

Domain _____

Range _____

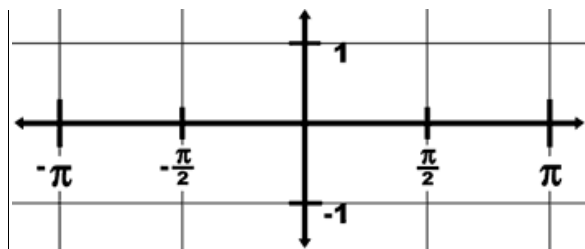

81. 82. $y = \cos x$

Domain _____

Range _____

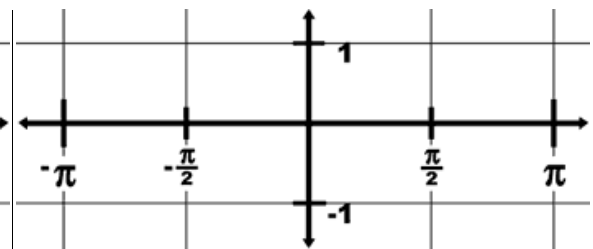

82. $y = \csc x$

Domain _____

Range _____

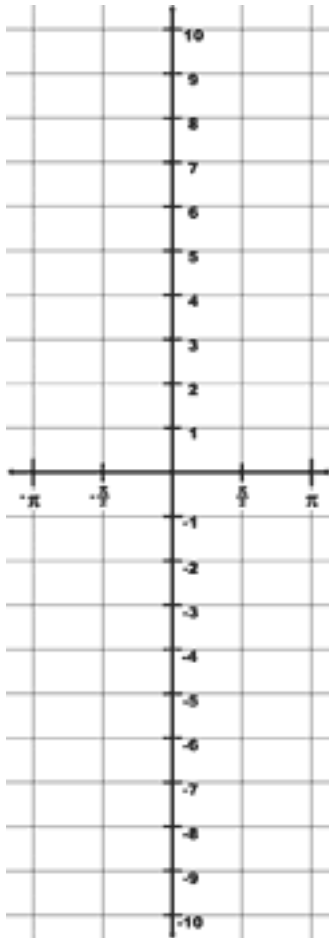

83. $y = \sec x$

Domain _____

Range _____

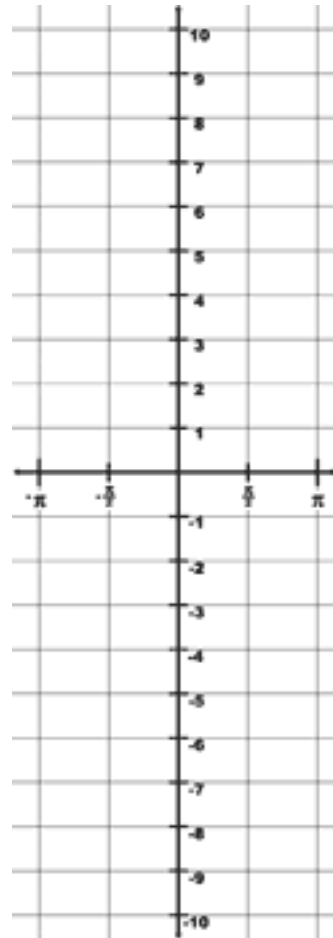

84. $y = \tan x$

Domain _____

Range _____

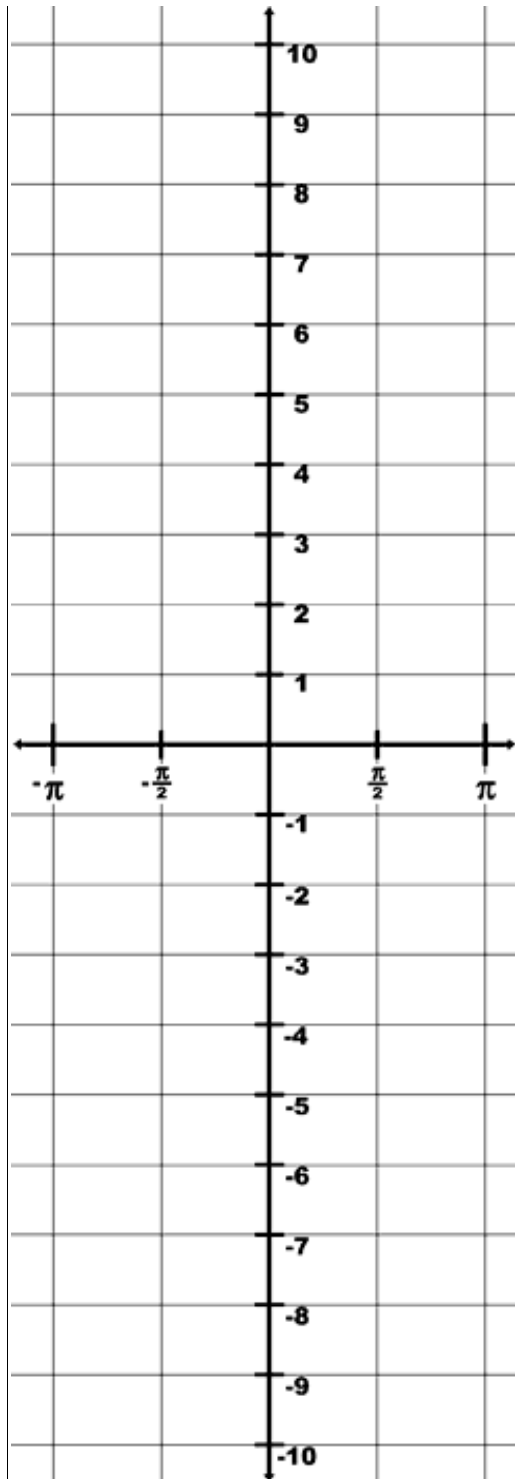

85. $y = \cot x$

Domain _____

Range _____

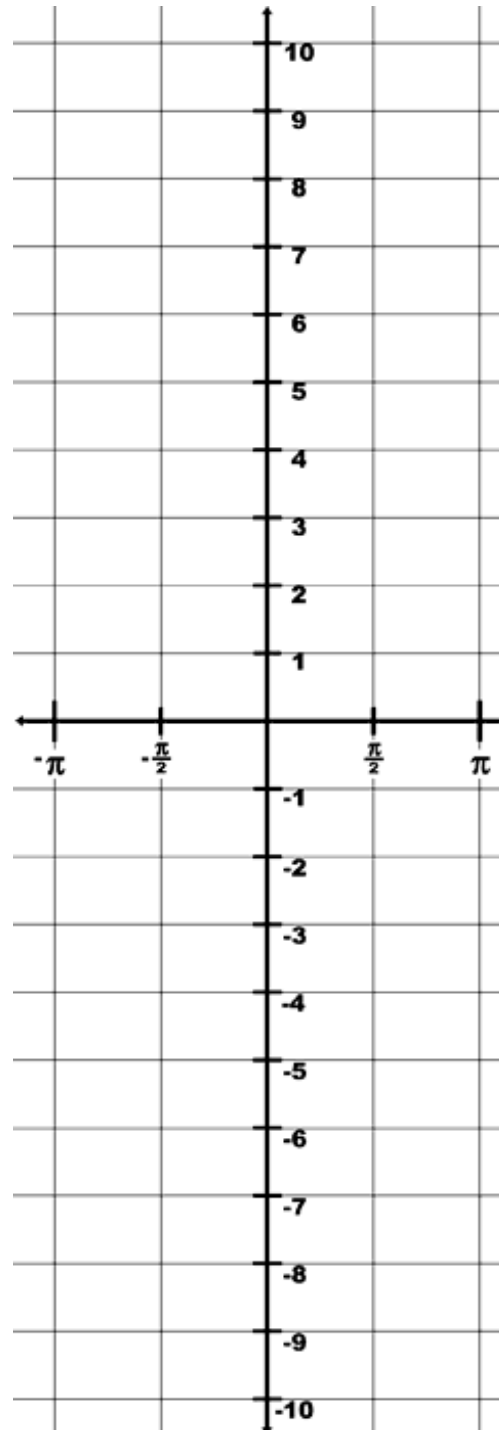

Section XIII: Solve for x and y in the triangles below.

86.

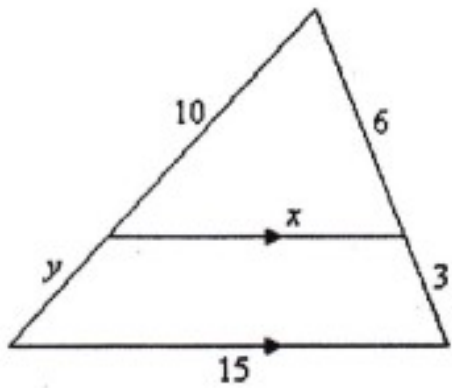

87.

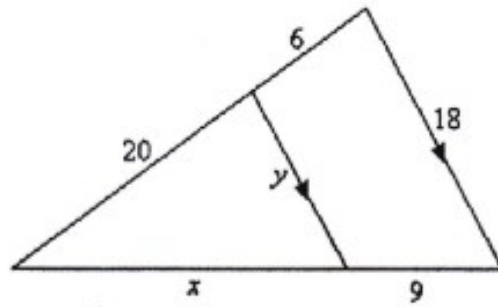

Section XIV: Find the area of the figures below. (Don't forget the units)

88.

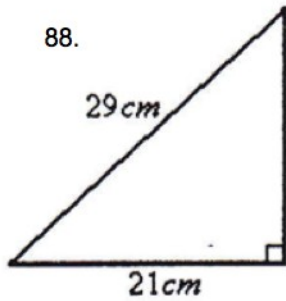

89.

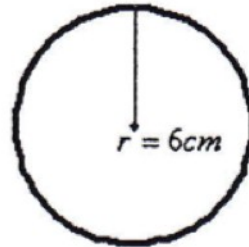

90.

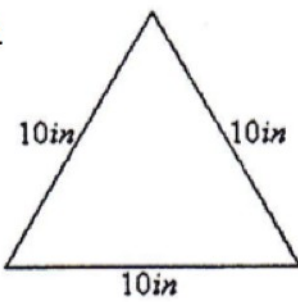

91.

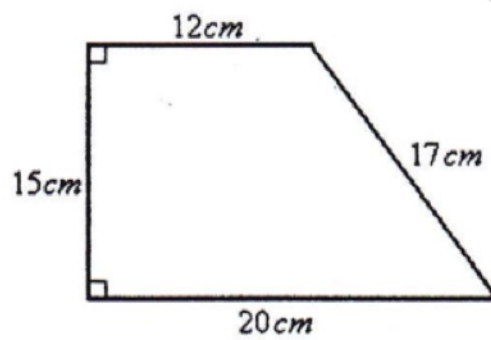

Section XV: Find the volume of the solids below. (Don't forget the units)

92.

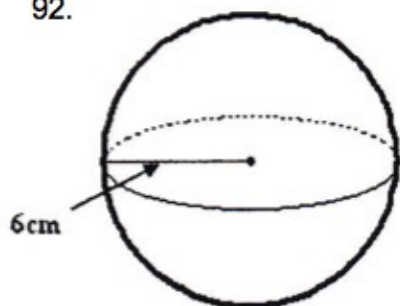

93.

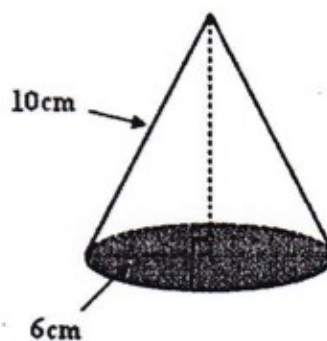

94.

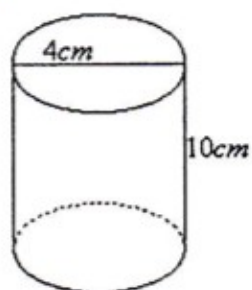

95.

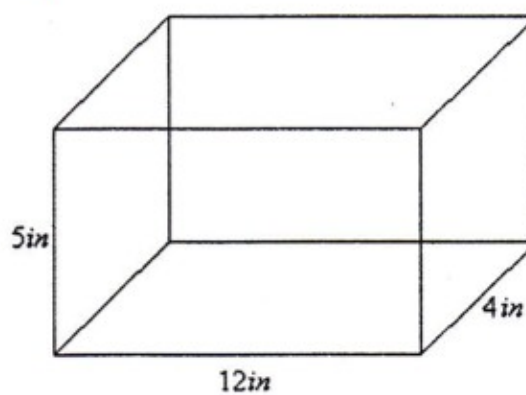

Section XVI: Misc. Short answer

96. One Civil War Mortar, the Dictator, could throw a 218 pound shell about two and one-half miles . The height of the shell (in feet) t seconds later is given by

$$h(t) = 1140t - 16t^2$$

- (a) Evaluate and interpret $h(20)$.
- (b) Solve the equation $h(t) = 5280$. Interpret your solutions and illustrate them on a graph of $h(t)$.
- (c) Find the maximum height the shell reaches and the corresponding time. Defend your answer algebraically.

97. Consider $f(x) = \frac{4x^4 + 2x^2 - 7x - 58}{x^3 - 2x^2}$

a. Find all asymptotes: Horizontal, vertical and oblique. Defend results algebraically.

b. Find all zeros. Defend results algebraically

c. Name the domain and range of $f(x)$ in interval notation.

98. One useful tool in looking at the graph of a trigonometric function is the ability to be able to look at only one cycle of the graph. For the function:

$$f(x) = 4 - \cos\left(2\left(x - \frac{\pi}{4}\right)\right)$$

what values for n , x_{\min} , x_{\max} , y_{\min} , y_{\max} would show

one complete cycle? Things you should address are amplitude, period, reflections, and shifts both horizontally and vertically. (Show analysis for each response)

99. Graph the function $f(x) = -\tan x$ on the interval $\left[-\pi/2, \frac{3\pi}{2}\right]$. Explain why

it is correct to say that f is decreasing on the interval $\left[\pi/2, \frac{3\pi}{2}\right]$, but it is

incorrect to say that f is decreasing on the interval $\left[-\pi/2, \frac{3\pi}{2}\right]$.

100. The point $(-1, \sqrt{3})$ is on the terminal ray of an angle of rotation. The initial ray is the positive x-axis. Express this angle of rotation in both radians and degrees. (Use exact values)